

**CNC Internal Grinding Machine**

 **YANG YI** 陽 鎰 機 械  
MACHINERY CO., LTD.

**YIG-200**



**YANG YI**  
**YIG-200**

**YIG-**

**Internal Grind**

## Advanced Technology! Excellent Precision and Efficiency!

### FIXED GRINDING SPINDLE

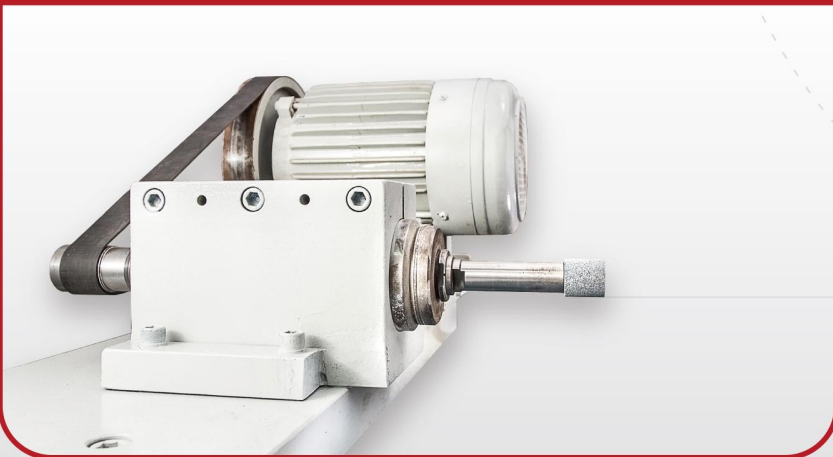

- Use a fixed grinding spindle to avoid having vibration errors when the spindle motor runs to make the precision more stable.

### DESIGN PATENT OF THREE-ROLLER

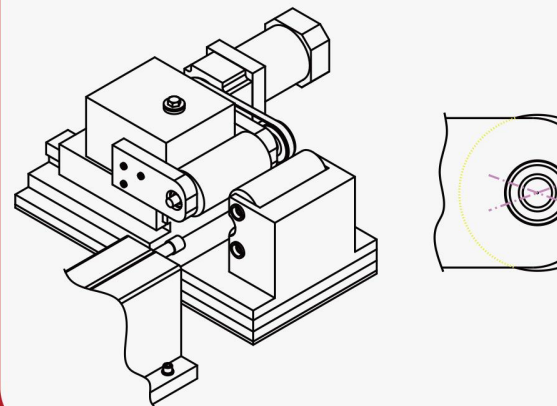

- No matter what the diameter of the workpiece, after putting on the fixture, the center of the workpiece is on the same line and the concentricity of the workpiece is the same workpiece is repeated pick

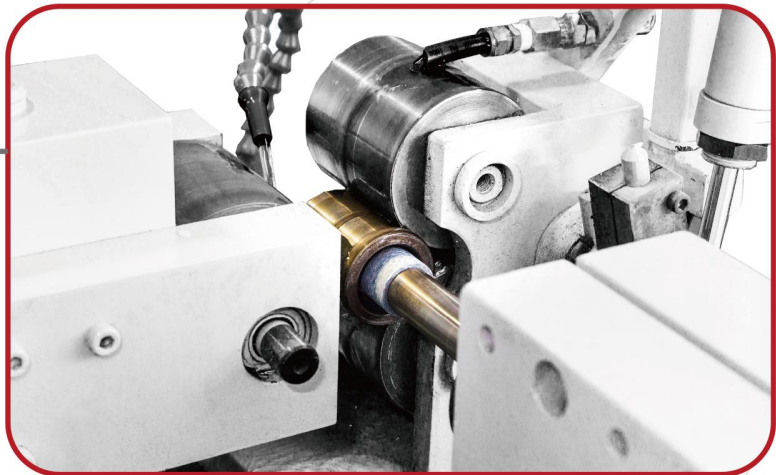

## 200 ing Machine

YIG-200 internal grinding machine is equipped with a SYNTEC CNC controller, and the grinding wheel feed which is driven by a high performance servo motor. Besides, YIG-200 adopts the high precision linear guideway and the ball screw transmission, which is capable of performing continuous grinding wheel dressing, auto compensation, and other fully-automatic processes. These functions provide precise accuracy and dressing efficiency. It also uses design patent of spindleless to clamp the structure and three-roller device that makes the operation more convenient.

### DEVICE

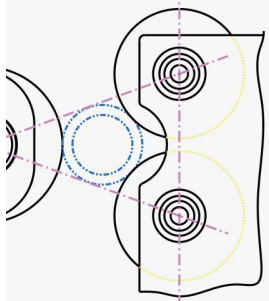

### HIGH PRECISION



- YIG-200 can actually meet the requirement of high precision.

workpiece is, when  
the circle will be on  
will not change when  
-and-place.



# YIG-200

## CNC Internal Grinding Machine

### Machine Specifications

Capacity	Range of I.D. Grinding	Ø15~100mm
	Max. Grinding Depth	250mm
	Max. Clamping Length	180mm
	Max. Clamping O.D.	200mm
	Min. Input Unit	0.001mm
Spindle	Spindle Speeds	9000~30000RPM
Travel	X-Axis	200mm
	Z-Axis	300mm
Motor	Spindle Motor	2.5kW
	X、Z-Axis Servo Motor	0.8kW
	Workhead Spindle	0.75kW
	Hydraulic Motor	0.75kW
	Cooling Pump Motor	0.12kW
Others	Power Supply	AC / 3PH / 220V / 5kW
	Machine Dimension	L1900*W1600*H1800mm
	Machine Weight (N.W.)	2500kg
	Coolant Tank	20L
	CNC Controller	SYNTEC 21TA

Yang Yi reserves the right to change specifications and design characteristics without prior notice.

Email : [service@yang-yi.com.tw](mailto:service@yang-yi.com.tw)

TEL : +886-4-25379877

FAX : +886-4-25379811

[www.yang-yi.com.tw](http://www.yang-yi.com.tw)